



PLANNING COMMISSION

AGENDA for December 13th 2022

AGENDA

REGULAR MEETING

Call to Order by Chairman and Roll Call

Public Comment

Review and Adoption of Minutes

October 11th and November 9th meetings

Report of Secretary

Old Business

- 1) Zoning Text Amendments related to Manufactured Homes

New Business

- 1) Conditional Use Permit for 1744 Cedar Ave

Adjournment

Members and Term Expirations

Dennis Hawes, Chairman, 7/31/2024

Harold Kidd, 6/30/2026

Justin Wiseman, 8/31/2025

Marolyn Cash, 6/30/2024

Lucy Ferrebee, 9/30/2023

Melvin Henson, City Council Representative,
9/30/2023

Kristie Gibbons, 12/31/2024

Timothy Petrie, 12/31/2024

Jason Tyree, Ex Officio member

Staff

Tom Roberts, Director of Community & Economic Development
City Hall, 2039 Sycamore Avenue, Buena Vista VA 24416
(540) 261-8607 | troberts@bvcity.org | buenvistava.org/planning

Meetings

Members of the Buena Vista Planning Commission meet in Council Chambers, 2039 Sycamore Avenue, at 7:00 p.m. on the 2nd Tuesday of each month, unless otherwise announced. Meetings may be held and business conducted without a quorum, but no votes may be taken unless a quorum is present. A majority of members constitutes a quorum. A motion passes with a majority vote; a tie constitutes defeat of the motion.



PLANNING COMMISSION

MINUTES of November 9th 2022

Members of the Buena Vista Planning Commission met in Council Chambers at 7:00 PM on Tuesday, November 9th 2022.

Members Present:

Dennis Hawes, Chairman
Lucy Ferrebee
Timothy Petrie
Melvin Henson, City Council Representative

Members Absent:

Harold Kidd
Marolyn Cash
Kristie Gibbons
Justin Wiseman
Jason Tyree, Ex Officio member

Staff Present:

Tom Roberts, Director of Community & Economic Development

Meeting is called into order and roll was called. There was not a quorum, so per the bylaws, the Commission can conduct business but cannot vote on any items.

Minutes

Mr. Petrie noted that he was not present at the October meeting. Mr. Wiseman moved to approve the minutes as amended, Mrs. Cash seconded, and all voted yes.

Public Comment

Mr. Andrew King rose to speak and asked that the Commission add to the zoning text amendment for manufactured housing the provision to allow manufactured homes by conditional use permit in R3.

There was a brief discussion about the process for modifying the draft text. Mr. Roberts explained that the Commission could vote to recommend approval of the text as it stands now (without the provision for R3) or recommend approval with certain changes (such as adding the provision for R3 back in). The next step will then be a City Council public hearing.

Secretary's Report

Mr. Roberts reported on multiple items:

- Today the contractor installed new landscaping on the north side of 29th Street near the railroad tracks, funded by the Virginia Trees for Clean Water grant.

- November 10th the landscape architect for the Town Square will have a public input table at the Farmer's Market with concept sketches

Public Hearing and Old Business

Manufactured Home zoning text amendment

There were no public comments. The Commission briefly discussed the manufactured home issue and Andrew King's request.

Mr. Petrie pointed out that the proposed text does address the goal of affordable housing through the R5 manufactured housing zone.

Mr. Roberts noted that there is not anywhere in the City currently zoned R5, but that he would consider rezoning the Hillside Manufactured Home Park (currently non-conforming use in R3) to R5 to make it conforming.

Mr. Roberts also explained that there are many programs that can assist low-income home owners or renters to purchase or improve their homes. He is working on assembling information on more resources to share with citizens because it is an important issue.

There was a brief discussion of next steps for the text amendment. The Commission will vote on this at the next meeting in December.

Adjournment 7:45 PM

Approved: _____



PLANNING COMMISSION Staff Report

Zoning Text Amendment
Manufactured Home Provisions
12/8/2022

Synopsis

Update multiple sections of the zoning code regarding manufactured homes to clarify language and process.

Summary:

- Refresh language in R5 Manufactured Home District, including clarifying procedures
- Refresh language in Section 707 Manufactured Homes, including updating design requirements for manufactured home parks
- Update setbacks and dimensional requirements and fold them into Table 1 of Section 630 instead of a separate table
- Add individual manufactured homes as a conditional use in C1 Conservation District, per state law
- Update definitions related to manufactured homes
- This version does NOT include the provision to allow manufactured homes by Conditional Use Permit in R3 Residential Limited zone

Recommendation

A public hearing was held on this item at the November 8th 2022 Planning Commission meeting. No new feedback or proposals were provided in the hearing or Commission discussion. There was not sufficient quorum to vote on the item so a vote is needed at the December meeting. Following this, the item will go to City Council public hearing January 5th 2023.



Section 606 Residential | Multiple Code Sections related to Manufactured Housing

Original text

9/19/2022

Sec. 606.00. Residential District R-5.

606.01 *Intent of the Residential District R-5.* The intent of the Residential District R-5 is to allow low cost residential development in the form of mobile home parks and mobile home subdivisions.

606.02 *Permitted uses.* Within Residential District R-5 the following uses are permitted:

606.02-1 Mobile home parks in accordance with article 7;

606.02-2 Mobile home subdivisions in accordance with article 7 and meeting the requirements of article 9;

606.02-3 Permanent buildings housing management offices, child care centers, laundry facilities, or indoor recreational facilities or other service facilities may be permitted, provided that:

(a) Parking requirements for such facilities are met;

(b) Such uses are subordinate to the residential use and character of the park.

606.02-4 Bed and breakfast homestays in accordance with article 14.

606.03 *Conditional uses.* When after review of an application and hearing thereon, in accordance with article 8 herein, the Buena Vista City Council find as a fact that the proposed use is compatible with surrounding uses, is consistent with the intent of this ordinance and of the comprehensive plan, is in the public interest, and will comply with all other provisions of law and ordinances of Buena Vista, the following uses may be permitted with appropriate conditions:

606.03-1 Neighborhood commercial uses provided they are designed and intended to meet the service needs of persons residing in the park or subdivision and its immediate neighborhood;

606.03-2 Commercial radio, television, and communication towers along with related buildings and equipment provided the requirements of article 13 are met;

606.03-3 Bed and breakfast inns in accordance with article 14.

606.04 *Accessory uses.* Where a lot is devoted to a permitted principal use, customary accessory uses and structures are authorized. The following rules are applicable:

606.04-1 Living quarters in main structure of persons employed on the premises;

606.04-2 Temporary office or storage building for use during construction, which shall be removed upon completion or abandonment of the construction work;

606.04-3 Signs as provided for in article 7;

606.04-4 Parking as provided for in article 7;

606.04-5 Existing structures to include towers, power towers, water tanks, telephone poles, commercial buildings and rooftops, may be used to affix commercial radio, television, and communication antennas provided the requirements of article 13 are met.

Sec. 707.00. - Mobile homes.

Any mobile home placed in the City of Buena Vista after the date of enactment or amendment of this ordinance, shall meet the following requirements:

707.00-1 All mobile homes shall meet the plumbing requirements and the electrical wiring and connection, construction, blocking, and anchoring requirements of the Virginia State Building Code and shall display the seal of a testing laboratory approved by the State of Virginia;

707.00-2 All mobile homes shall be completely skirted; such that no part of the undercarriage shall be visible to a casual observer, in accordance with methods and materials approved by the building official;

707.00-3 All mobile homes shall be supplied with public water and wastewater disposal or such individual service evidenced by permits from the health department.

707.01 Mobile home lot requirements.

707.01-1 Individual mobile home lot requirements are found in table 2.

707.02 Mobile home park and setback requirements. All mobile home parks shall meet the following minimum area and setback requirements:

707.02-1 All mobile home parks shall have a minimum area of at least three acres. A minimum of three spaces shall be completed and ready for occupancy before the first occupancy is permitted;

707.02-2 The overall density of any mobile home development shall not exceed seven units per gross acre. The density of any particular acre within such park shall not exceed eight units per gross acre;

707.02-3 No main or accessory building shall be located closer than 25 feet to any property line of a mobile home park.

707.03 Mobile home standard requirements. All mobile home stands shall meet the following requirements:

707.03-1 The area of any mobile home stand shall not be less than 3,400 square feet;

707.03-2 No mobile home or permanent building shall be closer than 7½ feet to any stand line;

707.03-3 The minimum length of a mobile home stand shall be 85 feet. The minimum width shall be 40 feet;

707.03-4 The rear yard of each mobile home stand may be provided with a clothesline which shall be exempt from setback and other requirements of mobile home accessory structures.

707.04 Mobile home accessory structures. All mobile home accessory structures erected or constructed after the date of enactment or amendment of this ordinance must meet the following requirements:

707.04-1 All mobile home accessory structures must meet the plumbing, electrical connection, wiring, construction, and other applicable requirements of the Building Code;

707.04-2 Except in the case of an awning, ramada, or other shade structure, where a mobile home accessory structure is attached to the mobile home unit, a substantial part of one wall of the accessory structure shall be flush with part of the mobile home unit, or such accessory structure shall be attached to the mobile home unit in a substantial manner by means of a roof. All mobile home accessory structures, whether attached or detached, shall be designed and constructed as freestanding structures. No detached mobile home accessory structure, except ramadas, shall be erected closer than 7½ feet to a mobile home;

707.04-3 Mobile home accessory structures, except ramadas, shall not exceed the height of the mobile home;

707.04-4 No mobile home accessory structure shall be erected or constructed on any mobile home lot or stand except as an accessory to a mobile home.

707.05 Mobile home park application and site plan. Applicants for mobile home parks shall meet the following special requirements:

707.05-1 Site plans shall be legibly drawn at a scale consistent with its purpose;

707.05-2 The following information shall be required of site plans:

a. The date of the site plan, the name of the surveyor and the number of sheets comprising the site plan;

b. The scale and the north designation;

c. The name and signature of the owner, and the name of the proposed park; said name shall not closely approximate that of any existing mobile home park or subdivision in the City of Buena Vista;

d. A vicinity map showing the location and area of the proposed park;

e. The boundary lines, area, and dimensions of the proposed park, with the locations of property line monuments shown;

f. The names of all adjoining property owners;

g. Proposed layout, including interior streets with dimensions and such typical street cross sections and centerline profiles as may be required in evaluating the street layout; water, sewer, drainage, and utility lines, facilities and connections, with dimensions shown; location and type of solid waste collection facilities; interior monuments and lot lines, dimensions, and areas of mobile home lots, common open space and recreation areas, common parking areas, and other common areas; locations and dimensions of mobile home stands and parking

spaces, managements offices, laundry facilities, recreation buildings, and other permanent structures; location and nature of fire-fighting facilities, including hydrants, fire extinguishers, and other fire fighting equipment; location of fuel storage facilities and structure of high flammability; and location and dimensions of landscaping amenities, including street lights, sidewalks, planted areas, significant natural features to be retained, and fencing and screening;

707.05-3 The site plan shall be accompanied by a narrative statement describing how the standards and requirements set forth herein are to be met; a statement from the health official certifying approval of the proposed site plan; and where appropriate, statements from the highway engineer certifying approval of the street and drainage; water and sewer, or utility system layouts by the owner/operator.

707.06 Mobile home park design standards.

707.06-1 *Streets.* An internal street system shall be provided to furnish convenient access to mobile home stands and other facilities in the park, shall be designed such that connection to existing drainage and utility systems is convenient, and shall meet the following requirements; in addition to such other reasonable standards and requirements as may be established by the city council;

- a. All internal streets shall be permanently paved with a durable, dust-proof, hard surface. Minimum pavement widths shall be 16 feet for streets;
- b. Dead end streets shall be limited in length to 600 feet, shall be provided with cul-de-sacs with turning areas of not less than 40 feet in radius;
- c. Streets shall be adapted to the topography, shall follow the contours of the land as nearly as possible, and shall have safe grades and alignments;
- d. Driveway entrances to mobile home parks from any public street or road shall conform to the current construction standards of the department of highways and transportation.

707.06-2 *Vehicle parking.* Off-street parking shall be provided for the use of occupants at the minimum ratio of 2.0 car spaces (each space containing a minimum of 180 square feet) for each mobile home. Each off-street parking space shall be paved or graveled and have unobstructed access to either a public or private street. On street parking is prohibited unless the paved street on which the mobile home fronts is expanded to accommodate additional parking lanes or parking bays.

707.06-3 *Lighting.* All streets and walkways within the mobile home development shall be lighted.

707.06-4 *Disposition of garbage and rubbish.* It shall be the responsibility of the mobile home park to collect or cause to be collected and disposed of garbage and rubbish as frequently as may be necessary. Dumpsters may be used with the approval of the health department, but shall be so located as to not be more than one hundred 50 (150) feet from any mobile home.

707.06-5 *Installation of storage tanks.* Gasoline, liquefied petroleum, gas, or oil storage tanks shall be so installed as to comply with all county, state and federal fire prevention and protection regulations.

707.06-6 *Open spaces.* Where mobile home lot sizes are relied on primarily to provide for open space, lots and stands shall be so grouped as to maximize the amount of usable space, while meeting the minimum yard requirements set forth in section 707.01 of this ordinance.

707.06-7 *Record of tenants for mobile home parks.* The operator of a mobile home park shall keep an accurate register of all tenants occupying mobile homes located in the park. The register shall show the name and permanent residence address of the owner and occupants of any mobile home located in the park; the make and registration of any mobile home; the time and date of arrival and departure; and such other information as might be necessary to provide information about the occupants of the mobile home. These records shall be open to the law enforcement officers and public officials whose duties necessitate acquisition of the information contained in the register. The register record for each occupant registered shall not be destroyed for a period of three years following the date of departure of the registrant from the park.

707.06-8 *Certificate of use and occupancy required.* No mobile home or accessory structure shall be occupied in any mobile home park until a certificate of occupancy shall have been issued by the city building inspector to the effect that the mobile home park or the portion thereof for which such certificate is requested is in compliance with all applicable provisions of this chapter and the Uniform Building Code. Such certificate shall not be issued until after the same has been approved by the health department, zoning administrator and other agencies concerned.

ORIGINAL

TABLE 2. CITY OF BUENA VISTA LOT REGULATIONS FOR MOBILE HOMES, PARKS, AND SUBDIVISIONS

[Dimensions]	Mobile Home Park	Stand within Park	Mobile Home Subdivision	Subdivision Mobile Home Lot
Area	130,680 sf (3 acres)	3,400 sf	435,600 sf	7,000 sf (5 acres) with approval of health official
Setback (see section 701.01-3)	25 feet	N/A	25 feet	20 feet
Frontage at the setback line	150 feet	40 feet	150 feet	50 feet
Side yard:				
One side	25 feet	7.5 feet	25 feet	11 feet
Both sides	50 feet	15 feet	50 feet	22 feet
Rear	25 feet	7.5 feet	25 feet	25 feet
Height	35 feet	35 feet	35 feet	35 feet
Accessory buildings	Not to exceed 35 feet in height	Not to exceed height of mobile home	Not to exceed 35 feet in height	Not to exceed 35 feet in height

ORIGINAL

Article 3 Definitions of Terms Used in This Ordinance

302.04-7 Dwelling, single-family, means a building designed for, or occupied exclusively by, one family

302.13-4 *Manufactured home, including mobile homes*, means a structure subject to federal regulation which is transportable in one or more sections; is eight (8) body feet or more in width and forty (40) body feet or more in length in the traveling mode, or is three hundred twenty (321) or more square feet when erected on site; is built on a permanent chassis; is designed to be used as a single-family dwelling, with or without a permanent foundation, when connected to the required utilities; and includes the plumbing, heating, air-conditioning, and electrical systems contained in the structure. For the purpose of this ordinance, manufactured homes shall be deemed to include mobile homes.

302.13-5 *Mobile home* means a manufactured dwelling unit designated for long-term occupancy and constructed originally with wheels for movement (whether or not such wheels have later been removed) and which has plumbing and electrical connections provided for attachment to outside systems. A camping vehicle or travel trailer shall not be considered a mobile home.

302.13-6 *Mobile home park* means any development in which space is leased providing for three or more mobile homes intended for residential use for a period of time longer than 30 days.

302.13-7 *Mobile home stand* means a plot of ground within a mobile home park designed to accommodate one mobile home.

302.13-8 *Mobile home subdivision* means any area designated to accommodate three or more mobile homes intended for residential use on lots owned by the mobile home owner.

ORIGINAL



Section 606 Residential | Multiple Code Sections related to Manufactured Housing

Draft text
11/2/2022

Sec. 606.00. Manufactured Home District R-5.

606.01 *Intent of the Residential District R-5.* The intent of the Residential District R-5 is to allow development of manufactured home parks and subdivisions. Manufactured home developments can provide affordable, detached single-family housing at a density greater than traditional site-built neighborhoods. Developments are encouraged to cluster homes and make creative use of lot arrangement and open space for attractive, efficient, cost-effective, and environmentally sensitive design. Developments must integrate harmoniously with surrounding development patterns.

606.02 *Permitted uses.* Within Residential District R-5 the following uses are permitted:

606.02-1 Manufactured home parks in accordance with article 7;

606.02-2 Single manufactured homes on individual lots

606.02-3 Bed and breakfast homestays in accordance with Section 714.

606.02-4. Child care centers and family day care homes. The main structure shall not be located closer than 50 feet from any residential lot;

606.02-5 Places of religious assembly

606.02-6 Professional offices for management of specific manufactured home developments

606.02-7 Indoor and outdoor recreation facilities primarily for use by residents of specific manufactured home developments

606.03 *Conditional uses.* When after review of an application and hearing thereon, in accordance with article 8 herein, the Buena Vista City Council find as a fact that the proposed use is compatible with surrounding uses, is consistent with the intent of this ordinance and of the comprehensive plan, is in the public interest, and will comply with all other provisions of law and ordinances of Buena Vista, the following uses may be permitted with appropriate conditions:

606.03-1 Neighborhood commercial uses provided they are designed and intended to meet the service needs of persons residing in the park or subdivision and its immediate neighborhood;

606.03-2 Commercial radio, television, and communication towers along with related buildings and equipment provided the requirements of article 13 are met;

606.03-3 Bed and breakfast inns in accordance with article 14.

606.04 *Accessory uses.* Where a lot is devoted to a permitted principal use, customary accessory uses and structures are authorized. The following rules are applicable:

606.04-1 Living quarters in main structure of persons employed on the premises;

606.04-2 Temporary office or storage building for use during construction, which shall be removed upon completion or abandonment of the construction work;

606.04-3 Signs as provided for in article 7;

606.04-4 Parking as provided for in article 7;

606.04-5 Existing structures to include towers, power towers, water tanks, telephone poles, commercial buildings and rooftops, may be used to affix commercial radio, television, and communication antennas provided the requirements of article 13 are met.

606.05 *Development standards.*

606.05-1 New manufactured home subdivision must adhere to Article 9, except where required improvements conflict with provisions of this zone.

Sec. 707.00. - Manufactured homes.

Any manufactured home placed in the City of Buena Vista after the date of enactment or amendment of this ordinance, shall meet the requirements of this section as applicable.

707.01 Individual manufactured home requirements

707.01-1 All mobile homes shall meet the plumbing requirements and the electrical wiring and connection, construction, blocking, and anchoring requirements of the Virginia State Building Code and shall display the seal of a testing laboratory approved by the State of Virginia;

707.01-2 All manufactured homes shall be completely skirted; such that no part of the undercarriage shall be visible to a casual observer, in accordance with methods and materials approved by the building official;

707.01-3 All manufactured homes shall be supplied with public water and wastewater disposal where it is available; or such individual service evidenced by permits from the health department.

707.02 Manufactured home park dimensional requirements. All manufactured home parks shall have a minimum area of at least three acres. A minimum of three spaces shall be completed and ready for occupancy before the first occupancy is permitted;

707.03 Manufactured home stand requirements. All manufactured home stands shall meet the following requirements:

707.03-1 The area of any manufactured home stand shall not be less than 3,400 square feet;

707.03-2 Required side setback is 15 feet on both sides combined, with no side less than five feet.

707.03-3 The minimum length of a manufactured home stand shall be 85 feet. The minimum width shall be 40 feet;

707.03-4 The rear yard of each manufactured home stand may be provided with a clothesline which shall be exempt from setback and other requirements of manufactured home accessory structures.

707.04 Manufactured home accessory structures. All manufactured home accessory structures erected or constructed after the date of enactment or amendment of this ordinance must meet the following requirements:

707.04-1 All manufactured home accessory structures must meet the plumbing, electrical connection, wiring, construction, and other applicable requirements of the Building Code;

707.04-2 Except in the case of an awning, ramada, or other shade structure, where a manufactured home accessory structure is attached to the manufactured home unit, a substantial part of one wall of the accessory structure shall be flush with part of the manufactured home unit, or such accessory structure shall be attached to the manufactured home unit in a substantial manner by means of a roof. All manufactured

home accessory structures, whether attached or detached, shall be designed and constructed as freestanding structures. No detached manufactured home accessory structure, except ramadas, shall be erected closer than 7½ feet to a manufactured home;

707.04-3 Manufactured home accessory structures, except ramadas, shall not exceed the height of the manufactured home;

707.04-4 No manufactured home accessory structure shall be erected or constructed on any manufactured home lot or stand except as an accessory to a manufactured home.

707.05 *Manufactured home park application and site plan.* Applicants for manufactured home parks shall meet the following special requirements:

707.05-1 Site plans shall be legibly drawn at a scale consistent with its purpose;

707.05-2 The following information shall be required of site plans:

- a. The date of the site plan, the name of the surveyor and the number of sheets comprising the site plan;
- b. The scale and the north designation;
- c. The name and signature of the owner, and the name of the proposed park; said name shall not closely approximate that of any existing manufactured home park or subdivision in the City of Buena Vista;
- d. A vicinity map showing the location and area of the proposed park;
- e. The boundary lines, area, and dimensions of the proposed park, with the locations of property line monuments shown;
- f. The names of all adjoining property owners;
- g. Proposed layout, including interior streets with dimensions and such typical street cross sections and centerline profiles as may be required in evaluating the street layout; water, sewer, drainage, and utility lines, facilities and connections, with dimensions shown; location and type of solid waste collection facilities; interior monuments and lot lines, dimensions, and areas of manufactured home lots, common open space and recreation areas, common parking areas, and other common areas; locations and dimensions of manufactured home stands and parking spaces, managements offices, laundry facilities, recreation buildings, and other permanent structures; location and nature of fire-fighting facilities, including hydrants, fire extinguishers, and other fire fighting equipment; location of fuel storage facilities and structure of high flammability; and location and dimensions of landscaping amenities, including street lights, sidewalks, planted areas, significant natural features to be retained, and fencing and screening;

707.05-3 The site plan shall be accompanied by a narrative statement describing how the standards and requirements set forth herein are to be met; a statement from the health official certifying approval of the proposed site plan; and where appropriate, statements from the highway engineer certifying approval of the street and drainage; water and sewer, or utility system layouts by the owner/operator.

707.06 Manufactured home park design standards.

707.06-1 Streets. An internal street system shall be provided to furnish convenient access to manufactured home stands and other facilities in the park, shall be designed such that connection to existing drainage and utility systems is convenient, and shall meet the following requirements; in addition to such other reasonable standards and requirements as may be established by the city council;

- a. Private streets shall be constructed, at a minimum, using the VDOT GS-4 Geometric Design Standards for Rural Local Road System or VDOT GS-8 Geometric Design Standards for Urban Local Street System. The Zoning Administrator must approve which standard is used.
- b. Public streets shall be constructed, at a minimum, using the applicable standard from the VDOT Road Design Manual Appendix B(1) Subdivision Street Design Guide or current equivalent. Acceptance of public streets is at the discretion of City Council.
- c. All internal streets shall be permanently paved with a durable, dust-proof, hard surface. Gravel, crushed stone, or similar is not permitted.
- d. Dead end streets shall be limited in length to 600 feet, shall be provided with cul-de-sacs with turning areas of not less than 40 feet in radius;
- e. Driveway entrances to manufactured home parks from any public street or road shall conform to the current geometric design and construction standards of the department of highways and transportation, unless otherwise approved by the City.

707.06-2 Vehicle parking. Off-street parking shall be provided for the use of occupants at the minimum ratio of 2.0 car spaces for each manufactured home. Each off-street parking space shall be paved or graveled and have unobstructed access to either a public or private street. On street parking is prohibited unless the paved street on which the manufactured home fronts is expanded to accommodate additional parking lanes or parking bays.

707.06-3 Lighting. All streets and walkways within the manufactured home development shall be lighted.

707.06-4 Disposition of garbage and rubbish. It shall be the responsibility of the manufactured home park to collect or cause to be collected and disposed of garbage and rubbish as frequently as may be necessary. Dumpsters may be used with the approval of the health department, but shall be so located as to not be more than 150 feet from any manufactured home.

707.06-5 Installation of storage tanks. Gasoline, liquefied petroleum, gas, or oil storage tanks shall be so installed as to comply with all city, state and federal fire prevention and protection regulations.

707.06-6 Open spaces. Open and green space shall be provided for community and recreational use by residents, protection of natural features and watercourses, and

stormwater management. A minimum of ten percent (10%) of the gross area of the manufactured home park shall be open space, exclusive of roads.

707.06-7 Pedestrian Circulation. Adequate provision for pedestrians is required. All stands must be serviced by a sidewalk, pedestrian path, or roadway designed for safe shared use by vehicles and pedestrians. The park must connect to adjacent external pedestrian infrastructure wherever possible.

707.07 Record of tenants for manufactured home parks. The operator of a manufactured home park shall keep an accurate register of all tenants occupying manufactured homes located in the park. The register shall show the name and permanent residence address of the owner and occupants of any manufactured home located in the park; the make and registration of any manufactured home; the time and date of arrival and departure; and such other information as might be necessary to provide information about the occupants of the manufactured home. These records shall be open to the law enforcement officers and public officials whose duties necessitate acquisition of the information contained in the register. The register record for each occupant registered shall not be destroyed for a period of three years following the date of departure of the registrant from the park.

707.08 Certificate of use and occupancy required. No manufactured home or accessory structure shall be occupied in any manufactured home park until a certificate of occupancy shall have been issued by the city building inspector to the effect that the manufactured home park or the portion thereof for which such certificate is requested is in compliance with all applicable provisions of this chapter and the Uniform Building Code. Such certificate shall not be issued until after the same has been approved by the health department, zoning administrator and other agencies concerned.

Sec. 601.00 – Conservation District C1

...

601.03 Conditional uses. When, after review of an application and hearing thereon, in accordance with article 8 herein, the Buena Vista city council finds as a fact that the proposed use is compatible with the surroundings use, is consistent with the intent of this ordinance and of the comprehensive plan, is in the public interest, and will comply with all other provisions of law and ordinances of Buena Vista, the following uses may be permitted with appropriate conditions:

601.03-1 Commercial radio, television, and communication towers along with related buildings and equipment provided the requirements of [section 713.00](#) are met.

601.03-2 ~~Repealed 6-8-2008.~~ Single manufactured homes on individual lots

...

[REPEAL TABLE 2]

[EXCERPT OF TABLE 1]

District	Permitted Use	Minimum Structure Requirement (see k below)	Public Water and Sewer	Other	Setback (see i below)	Frontage at the Setback Line	One Side	Two Sides	Rear	Max. Height	Main Building	Side Lot Line	Rear Lot Line	Height (a,b,c,d,e)	
R-5 Residential	Manufactured home subdivision individual lots	N/A	3400	20,000	20	40	5	15	20	35	1	1	1	35	Maximum density 10.5 units per acre

Article 3 Definitions of Terms Used in This Ordinance

302.04-7 Dwelling, single-family, means a building designed for, or occupied exclusively by, one family, other than a manufactured home or mobile home.

302.13-4 *Manufactured home* means a structure subject to federal regulation which is transportable in one or more sections; is eight (8) body feet or more in width and forty (40) body feet or more in length in the traveling mode, or is three hundred twenty (321) or more square feet when erected on site; is built on a permanent chassis; is designed to be used as a single-family dwelling, with or without a permanent foundation, when connected to the required utilities; and includes the plumbing, heating, air-conditioning, and electrical systems contained in the structure..

302.13-5 *Mobile home* means A structure, transportable in one (1) or more sections, not subject to federal regulations and constructed prior to June 15, 1976, which is constructed on a chassis for towing to the point of use and designed to be used, with or without permanent foundation, for continuous year-round occupancy as a single-family dwelling when connected to the required utilities. A camping vehicle or travel trailer shall not be considered a mobile home.

302.13-6 *Manufactured home park* means any development in which space is leased providing for three or more manufactured homes intended for residential use for a period of time longer than 30 days.

302.13-7 *Manufactured home stand* means a plot of ground within a manufactured home park designed to accommodate one manufactured home.

302.13-8 *Manufactured home subdivision* means any area designated to accommodate three or more manufactured homes intended for residential use on lots owned by the manufactured home owner.



PLANNING COMMISSION Staff Report

Conditional Use Permit

1744 Cedar Ave

12/1/2022

Synopsis

Applicant JeNeal Martin requests conditional use permit to allow up to 5 unrelated persons in a dwelling unit.

Site Information

Address/Tax Map:	1744 Cedar Ave	
Existing zoning:	R3 Residential Limited	
Existing land use:	Single Family Dwelling	
Proposed zoning:	R3 Residential Limited	
Proposed land use:	Single Family Dwelling with increased occupancy	
Surrounding zoning and land use:		
R3 Residential Limited single family dwellings		
Size:	1200 sf house, 1.5 lots (9,375 sf)	
Staff Recommendation:	Approve as presented	
Tentative Timeline	Preliminary Commission Discussion	12/13/2022
	Planning Commission Public Hearing	1/10/2023
	City Council Public Hearing	2/2/2023
	City Council Adoption	2/16/2023

Overview

Proposal

The applicant proposes to house up to five unrelated adult residents in this single-family dwelling. By right, dwelling units may only be occupied by a family, as defined by the zoning code, which limits occupancy to four unrelated persons.

The property is a one story, 1,200 sf home on 1.5 city lots with 3 bedrooms and two bathrooms.

Details

Purpose

The applicants seek a Conditional Use Permit (CUP) to allow more than four unrelated adults to reside in the house at 1744 Cedar Ave to maximize use of the rooms and square footage of the dwelling and increase rental revenue.

Comprehensive Plan Conformance

The subject property is located within the R3 Residential Limited zone. The future land use map recommends this neighborhood remaining medium-density residential, which it identifies as 4.65 to 11.15 dwelling units per acre. R3 is characterized by detached single-family dwellings, which are allowed by right, but the zone also features multiple scattered two-, three-, and four-family dwellings.

The comprehensive plan offers the following policy for residential properties in the Land Use chapter: "When conversion of single-family houses to multifamily is permitted, appropriate off-street parking should be required. Converting front yard areas to parking lots is not in the best interests of the area." While this CUP is not for multiple dwelling units, there are likely to be more vehicles than in a house occupied by a family (as defined by the zoning code).

Surrounding Land Uses

The surrounding houses are single-family residential of similar size/square footage.

Infrastructure, Access, and Parking

Existing water and sewer provision is adequate for the proposed occupancy.

Off-street parking will be provided in a driveway on the left (north) side of the property off of Cedar Ave. Applicant is still working on a design for 3-4 spaces in the off-street driveway. There are two or three on-street parking spaces (depending on driveway width) in front of the house as well.

Analysis

Adding one additional occupant to this house will only slightly increase the level of activity above the by-right occupancy of a single family home. The floorplan is adequate to allow five occupants, and the bedrooms meet building code requirements for two occupants. The primary issue is providing sufficient off-street parking so that if all five residents have vehicles, they are not using excess on-street parking.

Staff recommend approval as presented, pending appropriate driveway design.



Any determination of topography or contours, or any depiction of physical improvements, property lines or boundaries is for general information only and shall not be used for the design, modification, or construction of improvements to real property or for flood plain determination.

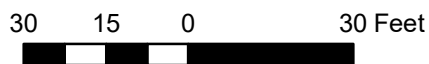

1744 Cedar Ave

12/8/2022

1744 CEDAR AVE, BUENA VISTA

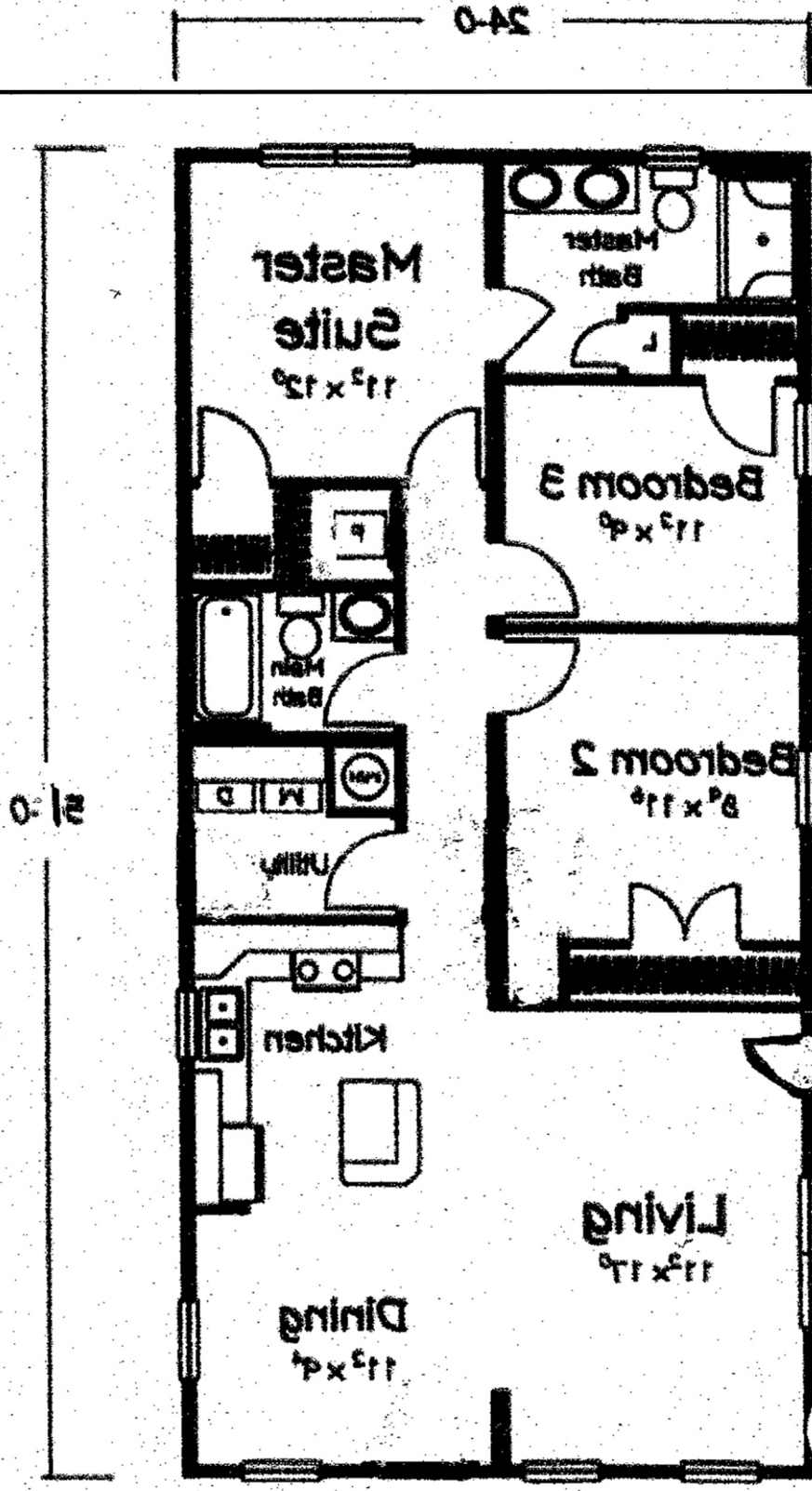

125'

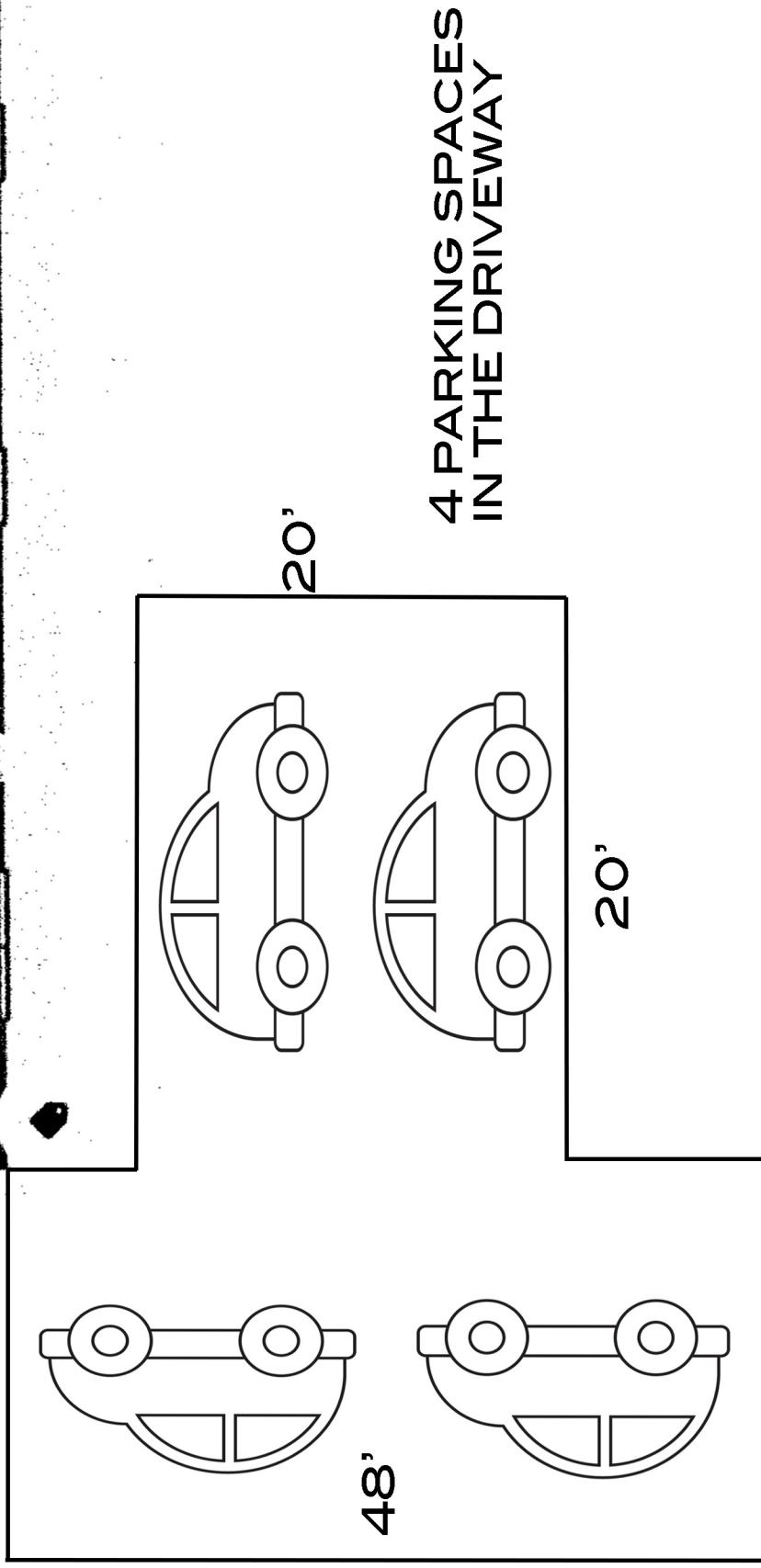

HOME SIZE: 1,224 SQ FT
LOT SIZE: 9,148 SQ FT

3'

14'

75'

2 PARKING SPACES ON THE SIDE OF THE ROAD

1/4 to 1'

REC
NOV 05 2020

50'

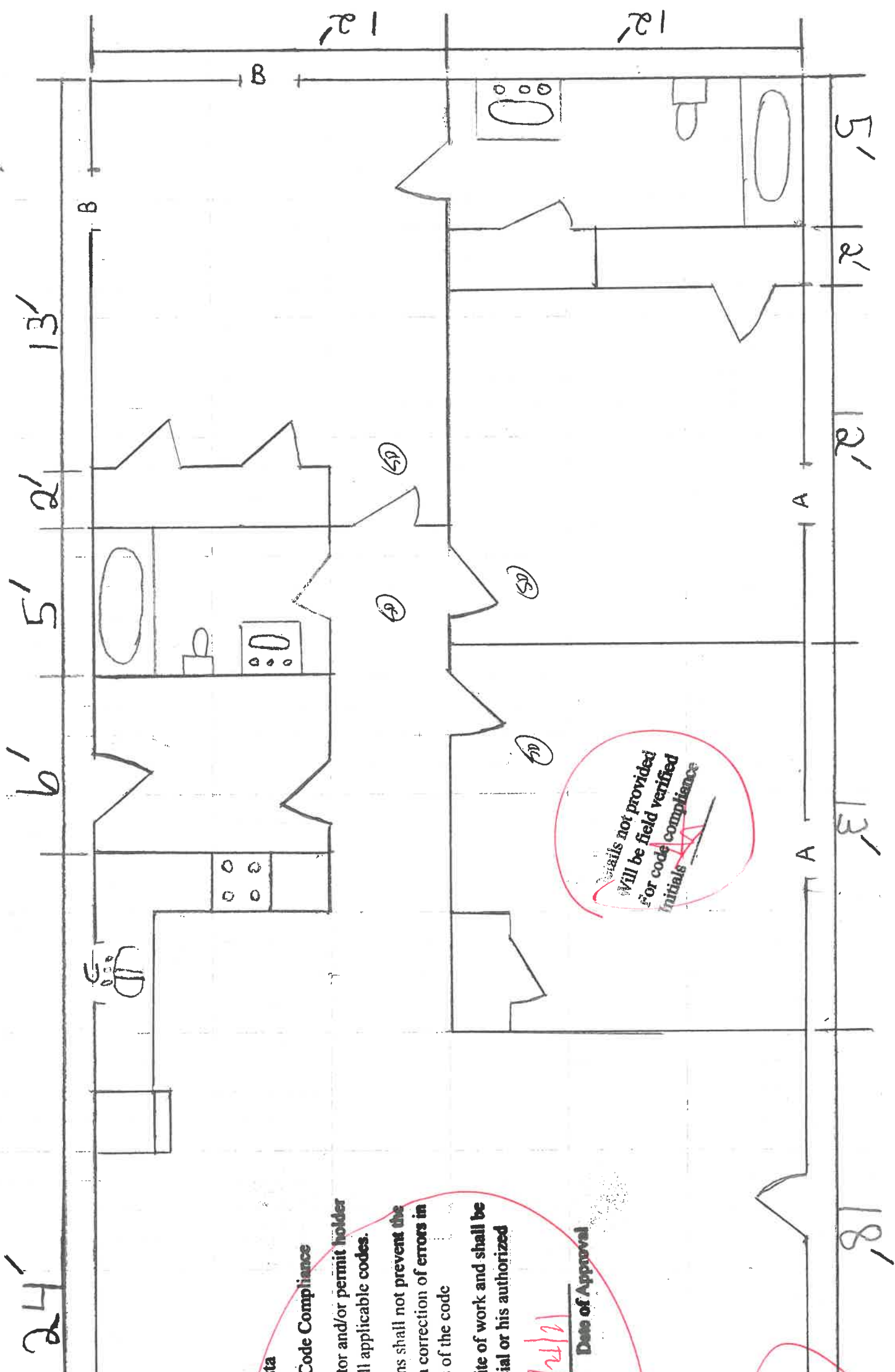

The City of Buena Vista

These Plans Have Been Reviewed for Code Compliance

This plan review does not relieve the contractor and/or permit holder from his responsibility to comply with all applicable codes.

The issuance of a permit based on these plans shall not prevent the Building Official from thereafter requiring a correction of errors in plans construction, or violations of the code

This copy of the plans must be kept at the site of work and shall be open to inspection by the Building Official or his authorized representative

9/24/21

Date of Approval

Building Official

**BUENA VISTA
BUILDING DEPARTMENT
2039 Sycamore Ave.
Buena Vista, Virginia 24416**

**APPROVED BUILDING PLANS
ARE REQUIRED TO BE ON
JOB SITE AT ALL TIMES**

Window Key

A - 28 50

B - 28 46

C - 28 30